

### BARN DOOR SAFARI FITTING INSTRUCTION

If your safaris were supplied by us in black primer, they have been acid etched and had a coat of 2k primer. They should be keyed with scotch pad, primered and finally top coated. We recommend you paint them **after** they have been installed. **.DO NOT POWDER COAT YOUR SAFARIS.** The temperature required for powder coating will cause the adhesive holding the hinge to the frame to fail. It is perfectly OK to use 2pack paint that is cured in a low bake oven.

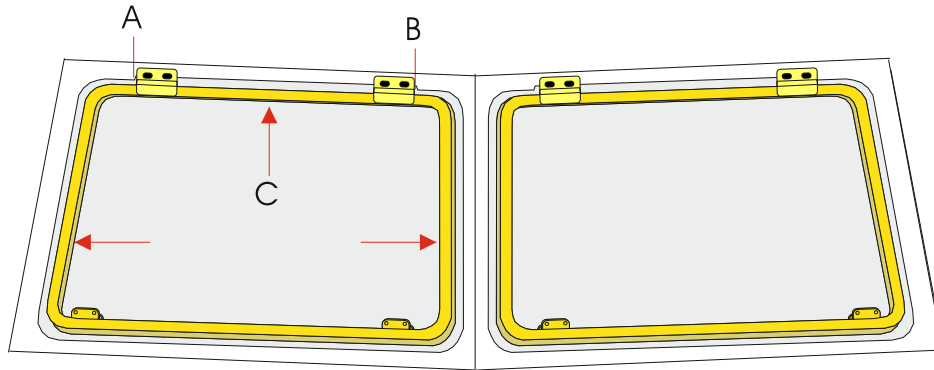

①

We recommend that you install the frames before you fit the glass.

The first thing to do is to centre the frame in your bus. Move the frame until you have equal clearance on both the left and right hand sides. Carefully mark points A & B, the ends of the hinge, so you always return to the centre position. A fine felt pen or pencil is best. Be sure to keep the hinge pushed upwards against the body whilst marking. (C)

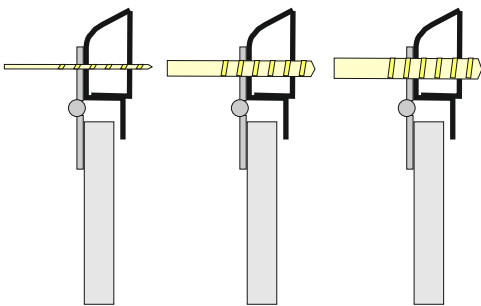

Centre window frame in aperture. Pilot drill a 3mm hole through hinge holes through both outer and inner skins making sure drill id level.

Open up Pilot hole to 6mm through both outer and inner skins making sure drill id level.

Open up 6mm hole to 10 mm through both outer and inner skins making sure drill id level.

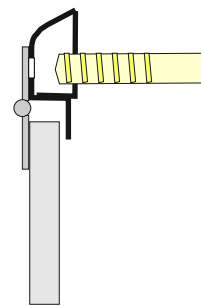

Open INNER HOLE ONLY to 12mm

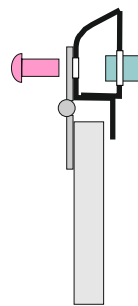

Insert special Dome nut from outside and then insert tube from inside so the tube protects your body work from crushing.

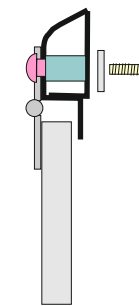

You can now use the machine screw and washer to secure.

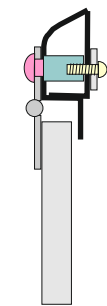

Completed assembly

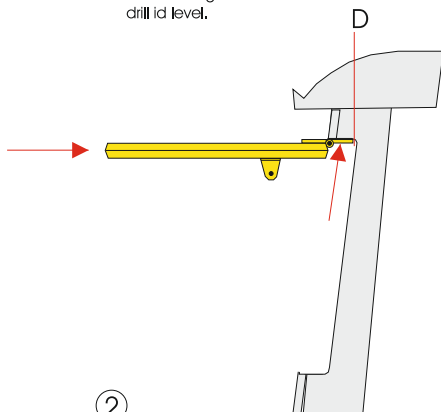

②

With the window centred on the marks A & B, carefully open the Safari ready to scribe through the holes in the hinge. Before you scribe the hole positions, be sure to push the window into the aperture so that the hinge "bottoms out" at the back of the recess D. Keeping the frame centred on A& B, scribe the hole locations. Drill the holes using a 2mm drill bit. When you have drilled them all, open up preferably to 2.5mm or 3mm. The 2.5drill will give more grip to the screws.

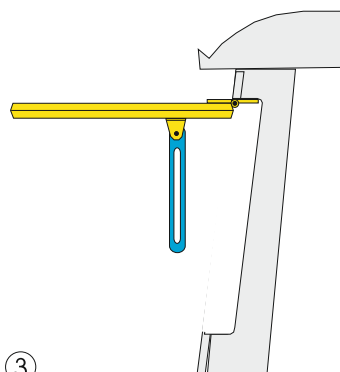

③

With the window secured with screws, attach the slides to the bracket on the frame.. Use the nylon washers provided on either side of the slide and do not over tighten the bolt so the slide can swing freely.

④

With the window secured and the slide attached, you can now fit the body bracket. Place the wing bolt through the slide and loosely into the body bracket. Move the bracket up the slide to the top of the slot. This is the position where the body bracket can be fixed. Repeat other side. The body bracket is best welded but will be ok if screwed or rivetted to your door.