

## REAR SAFARI FITTING INSTRUCTIONS

These instructions although showing a large rear Safari, apply to both early small and 23w Safaris.

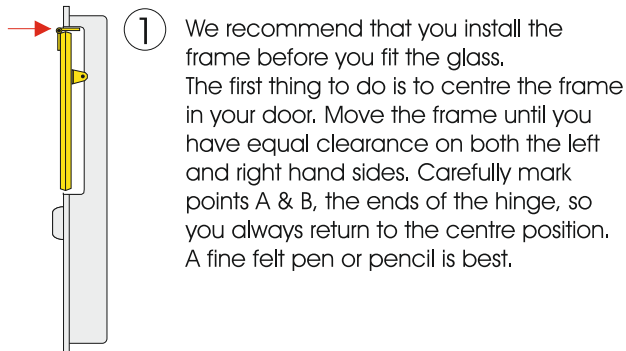

- ① We recommend that you install the frame before you fit the glass. The first thing to do is to centre the frame in your door. Move the frame until you have equal clearance on both the left and right hand sides. Carefully mark points A & B, the ends of the hinge, so you always return to the centre position. A fine felt pen or pencil is best.

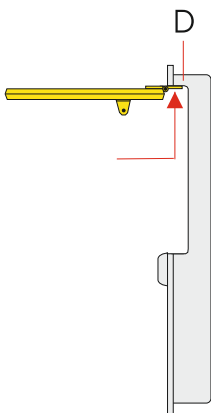
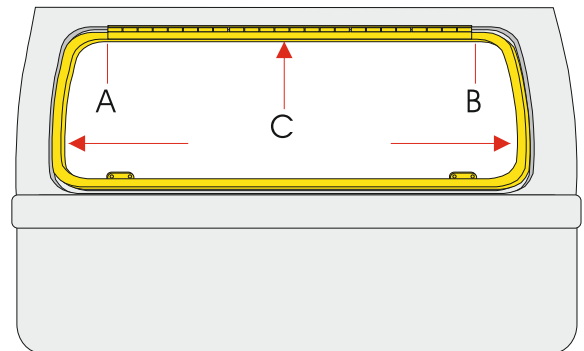

- ② With the window centred on the marks A & B, carefully open the Safari ready to scribe through the holes in the hinge. Before you scribe the hole positions, be sure to push the window into the aperture so that the hinge "bottoms out" at the back of the recess D. Keeping the frame centred on A&B, scribe the hole locations. Drill the holes using a 2mm drill bit. When you have drilled them all, open up preferably to 2.5mm or 3mm. The 2.5mm drill will give more grip to the screws.

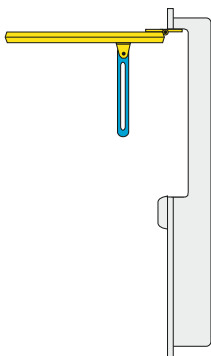

- ③ With the window secured with screws, attach the slides to the bracket on the frame. Use the nylon washers provided on either side of the slide and do not over tighten the bolt so the slide can swing freely.

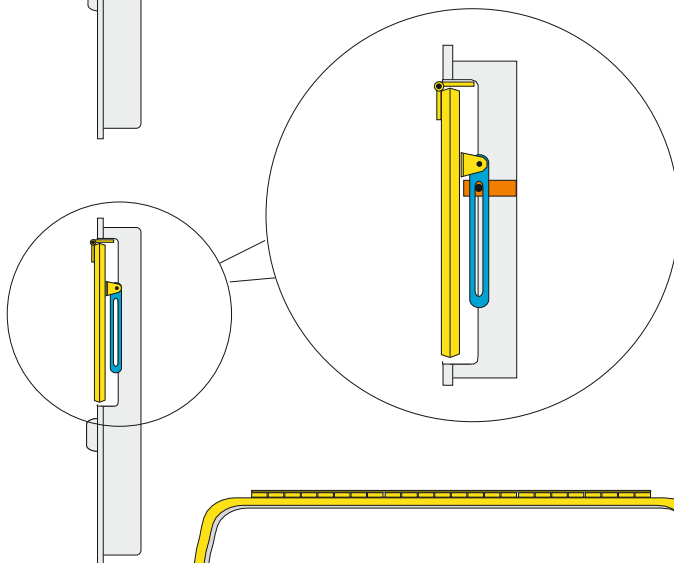

- ④ With the window secured and the slide attached, you can now fit the body bracket. Place the wing bolt through the slide and loosely into the body bracket. Move the bracket up the slide to the top of the slot. This is the position where the body bracket can be fixed. Repeat other side. The body bracket is best welded but will be ok if screwed or rivetted to your door.

Remove window and glaze.

Install rubber seal by starting dead centre at the top. Work round the aperture being sure to push the seal fully on to the steel lip. Use a small wooden or nylon hammer if needed. Trim the seal.

Install the glazed window and fit the catches with the levers pointing towards each other. With the catches on the frame, position the catch clips underneath the catches, mark through holes, drill and secure.

Your installation is now complete.

